

SERIAL #: \_\_\_\_\_  
ENGINE #: \_\_\_\_\_

# **M48**

## **HYUNDAI**

### **OWNERS**

### **MANUAL**

# WARNING

- Q[ ] ^|æáÁ ]|[] ^| | É@Á æ@ ^Á æ Áæ • ^Á ^|á ~ • Á b | ^ Á | Á ^æÉ
- Ö[ Á [ ó ^æÁ [ • ^Á & [ @ } Á ] ^|æá \* Á @Á æ@ ^ É Á Á æ Á & { ^ ^ } æ \* | á Á Á @ Á ~ á { ^ } É
- Úæ Á ^æ Á Á [ çá \* Á æó Á @ } Á @Á æ@ ^ Á } } á \* É
- ÖŠY ÖYÜÁ } -á { Á @Á æ@ ^ Á Ú @ Á á Á |[] ^| | Á ^ & | á Á ^ | ^ Á ^ | çá \* É
- ÖŠY ÖYÜÁ ^æ Á æ ^ Á |æ • ^ • É [ ~ } á Á | [ ç & ] Á æ Á | \* • É á Á | [ ç & ] Ç [ ç • É á Á ^ | É ^ á Á [ • Á @ } Á ] ^|æá \* Á @Á æ@ ^ É
- ÞÖXÖÜÁ çá á Á Á æ ^ Á @ Á ] ^|æá \* Á @Á æ@ ^ Á ÖŠÖÖVÜÖÁ UÖÖŠÉ
- ÖŠY ÖYÜÁ • ^ Á |[] ^| | Á | ~ } á á Á [ , ^ | Á | á • Á ÖŠÖÖVÜÖÁ UÖÖŠÉ
- Ú [ , ^ | Á | á • Á @ ~ | á ÖŠY ÖYÜÁ ^ Á @ Á |[] ^| Á á Á æ \* ^ Á | Á æ @ Á æ æ | æ á ] | æ á } Á ÖŠÖÖVÜÖÁ UÖÖŠÉ
- ÖŠŠÁ çá } • á } Á | á • Á @ ~ | á Á Á | \* ^ á Á ç Á á [ ~ } á Á æ | á ç | ~ ] ç | Á ÖŠÖÖVÜÖÁ T UÖÖŠÉ
- ÞÖXÖÜÁ • ^ Á çá } • á } Á | á • Á @ á Á Á ^ Á æ Á æ æ ^ á É æ ^ á | Á ÖŠÖÖVÜÖÁ T UÖÖŠÉ
- ÖŠY ÖYÜÁ • ^ Á @ Á |[] ^| | Á & çá \* Á ÜÜT Á Á ^ á á á Á [ ~ | Á | æ ^ Á á ~ æ ç | ^ É
- ÖŠY ÖYÜÁ @ Á - Á @ Á æ@ ^ Á ^ | ^ Á @ } \* á \* Á @ Á | æ ^ Á V P Ú Š W Ö Ö Š Ö Ö V Ü Ö Á T U Ö Ö Š Á ^ | ^ Á @ } \* á \* Á @ Á | æ ^ Á É
- Ö } ~ | ^ Á |[] ^| Á [ • á } Á á Á ^ & | æ Á - ÖŠŠÁ æ ^ Á ~ æ á • Á ^ | ^ Á ] ^|æá \* Á @ { æ@ ^ É
- ÖŠY ÖYÜÁ • ] ^ & @ Á æ@ ^ Á ^ | ^ Á • ^ Á | Á æ ^ Á ] ^|æá } É
- ÖÜÖÁ P ÖZÖÜÖÁ • ] ^ & Á | Á ^ Á æ á \* Á ~ á • Á ç æ É á á á á Á & É | á | Á Á ] ^|æá } Á ~ ç @ Á æ@ ^ É

**WARNING Continued**

- **WARNING:** Do not operate this equipment if you are under the age of 18. Do not drink alcohol or use drugs before operating this equipment.

**THIS EQUIPMENT SHOULD NOT BE OPERATED BY ANYONE UNDER THE AGE OF 18.**

# **LIMITED WARRANTY**

**WARRANTY:**

This limited warranty covers the original purchaser of this equipment for a period of 90 days from the date of purchase. It covers defects in materials and workmanship under normal use and service. This warranty does not cover damage caused by misuse, abuse, neglect, or unauthorized repairs.

**WARRANTY ADJUSTMENTS:**

For any defect covered by this warranty, we will repair or replace the part at our discretion. We are not responsible for labor charges or transportation costs. We will not be held liable for consequential or incidental damages. This warranty is void if the equipment is used for commercial purposes.

This warranty is limited to the original purchaser and is not transferable. It is void if the equipment is used for commercial purposes. We are not responsible for damage caused by misuse, abuse, neglect, or unauthorized repairs.

For more information, please contact us at the address below. We are not responsible for damage caused by misuse, abuse, neglect, or unauthorized repairs.

**Morley Equipment Company**  
41161 Sandalwood Circle, Murrieta, CA 92562  
(951) 894-5558

**EXCLUSIONS FROM WARRANTY:**

This warranty does not cover damage caused by misuse, abuse, neglect, or unauthorized repairs. It does not cover consequential or incidental damages. This warranty is void if the equipment is used for commercial purposes.

# M48 SAW INFORMATION

- This Manual provides the basic instructions for the operation and maintenance of the M48 concrete saw. All saw manuals are also available for download on our website at [www.morleysaws.com](http://www.morleysaws.com). An engine manual is also provided with each saw.

- M48 - WATERCOOLED:**

ENGINE:	Hyundai ZPP 416 - Gas
Drive Unit:	Hydrostatic Transmission
Water Pump:	Self-priming Electric (Optional)
Spindle:	1-7/16"
Arbor Size:	1" with 1/4" Keys
Blade Capacity:	14" to 36" Diameter
Depth Control:	Hydraulic Raise/Lower Depth Gauge and Locking Stop
Fuel Capacity:	5-Gallons
Weight:	Single Speed: 1,040 Lbs, 3-Speed: 1,130 Lbs
Length:	43"
Width:	29" w/Quick Detach Spindle
Height:	44"

### **OPTIONAL EQUIPMENT**

- 3-Speed Gearbox
- Night Light
- Bladeguards - 26", 30", and 36"
- Electric Water Pump

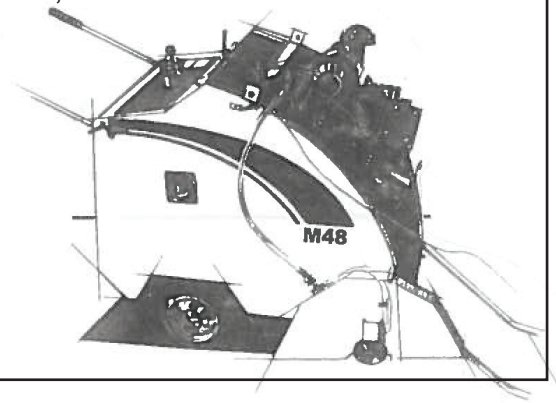

- The new machine was test-run before leaving Morley Equipment Company, however, check all fluid levels before operation.

- LUBRICATION/SERVICE CHART**

<b>ITEM</b>	<b>CHECK</b>	<b>LUBRICANT</b>
Hydrostatic Drive (F/R)	Monthly	20W-50 Motor Oil
Air Filter	Weekly	Service as required
Hydraulic Pump (R/L)	Monthly	ATF
Spindle Bearings	Daily	Grease
Pivot Axle	Weekly	Grease
Front Wheels	Weekly	Grease
Radiator	Weekly	Check coolant levels
Gear Box	Monthly	85W 140 gear oil

5. To adjust or replace the belts, loosen the 1/2" "pinch" bolts, one on either side at the front of the motor base plate, and the two 5/8" bolts that run vertical at the front of the motor plate. This allows the motor to be raised or lowered, loosening the belts for replacement or tensioning. Then raise the motor and tighten the bolts after belt replacement or to adjust tension. It is important that the tension is just enough to drive without slipping. Too tight shortens bearing life, too loose shortens belt life (Spindleshafte Belts -(6) 3VX425, Single Speed & 3-Speed.)

## **CONTROL OPERATING INSTRUCTIONS**

1. **WATER SUPPLY:** Connect the water supply to the inlet fitting, and open the water valve to control the flow.
2. **RAISE/LOWER:** By pulling back the Raise/Lower lever, a handle activates a hydraulic pump to raise the saw. Push the lever forward to lower the saw. You can control the lowering speed by opening the valve gradually. For adjusting the handle assembly, see Raise/Lower Valve Adjustment page.
3. **SPEED CONTROL:** The Forward/Reverse lever determines forward and reverse speeds, with a "neutral" position in between. By pushing the speed control lever forward, the saw will move forward at variable speeds. Pulling the lever back does the same in reverse.
4. **BLADE FITTING:** Remove spindle nut with provided blade wrench. On the right hand side of the machine is the reverse thread. Install blade and tighten nut with wrench and hammer provided. Ensure blade guard is secure before starting.
5. **STARTING THE ENGINE:** See Engine Manual.
6. **POSITIONING THE SAW:** This is a rear-pivot saw. It's designed to be maneuvered on the rear wheels. Position the handlebars to suit the operator. Pushing down on the handlebars will lift the front wheels off the ground, allowing you to maneuver the saw left or right.

7. **CUTTING:** Lay out the cuts using a chalk line or string and paint. Align your pointer guide with the blade, pointer guides do not come aligned from the factory. When aligned and positioned, turn on the water and lower the saw to desired cut depth, then drive the saw forward to a comfortable cutting speed. It is recommended to step-cut - i.e. take several passes to reach desired depth. If step-cutting, return the saw to the original insertion point and lower the blade to the secondary depth and repeat the cut.
8. **CLEANING:** The entire saw should be thoroughly washed weekly or as required. Use caution when cleaning near the electrical components. Be sure to clear any debris -dust, slurry, etc. - out of the radiator's cooling fins as required.
9. **STORAGE:** Always lubricate the saw after cleaning. A fine coat of WD40 will help remove future slurry.
10. **CALIBRATION:** Always check alignment. The spindleshaf and rear axles must be aligned to insure the saw travels straight and the blade moves parallel to the rear wheels.
11. **REPLACEMENT PARTS:** All replacement parts must be ordered from Morley Equipment Company or an authorized distributor to effect Warranty. Please supply saw Model and Serial Number if possible when ordering parts.
12. **QUESTIONS AND CONCERNS:** Should you have any questions relative to the operation or servicing of your equipment, do not hesitate to contact **Morley Equipment Company** at (951) 894-5558; or Email us at [morleyequipco@gmail.com](mailto:morleyequipco@gmail.com). A Parts List for the saw is also available online at [www.morleysaws.com](http://www.morleysaws.com).

# M48 PARTS LIST

## **SPINDLESHAFT ASSEMBLY**

<b>PARTS#</b>	<b>REQUIRED</b>	<b>DESCRIPTION</b>
1100-48	1	Spindleshaft
1101-48	2	Pillow-blocking Bearing
1115-48	2	4 1/2" Inner Collar
1116-48	2	4 1/2" Outer Collar
1104-48	1	Left-hand Nut
1105-48	1	Right-hand Nut
1106-48	1	Sheave
1107-48	1	Bushing
1120-48	1	Key - 3/8"
1109-48	2	Key - 1/4"
1111-48	6	3VX 425 Belt
1118-48	1	Left-hand Spindle Stud
1119-48	1	Right-hand Spindle Stud

## **FRONT AXLE ASSEMBLY**

5100-48	1	Weldment
2112-48	2	Axle - 1"
3002-48	2	Front Wheel - 6" x 2"
5004-48	2	Collar - 1"
2104-48	2	Pillow-block Bearing - 1"
2105-48	1	Pin - 5/8"x3.5"
2106-48	1	Depth Gauge, Cable, and Spring
2114-48	1	Pin - 5/8"x3"

## **HYDRAULIC RAISE/LOWER ASSEMBLY**

3100-48	1	Pump Motor
3101-48	1	Flow Control Valve
3102-48	1	Hydraulic Cylinder
3103-48	1	Raise/Lower Assembly
3106-48	1	Solenoid

## HYDROSTATIC DRIVE ASSEMBLY

PART#	REQUIRED	DESCRIPTION
4100-48	1	Pump
4101-48	2	Wheel Motor
4102-48	1	Positraction Manifold
4103-48	2	Wheel Hub
3001-48	2	Wheel - 10"x3"
4105-48	1	Filter Assembly
4106-48	1	Filter - Hydrostatic Oil
4107-48	1	Reservoir - Plastic
4201-48	1	Forward/Reverse Lever Assembly
4109-48	1	Drive Cable 26"
4110-48	2	Drive Cable 33"
4111-48	1	Hydrostatic Pump Belt – 4L3400 or A-32
4112-48	1	Wheel Motor Bracket
4113-48	1	Hydrostatic Drive Pump Bracket
41010-48	2	Cable End - Balljoint

## POINTER ASSEMBLY

5100-48	1	Weldment
5101-48	1	3" Pointer Wheel
5102-48	2	Delrin Bushing
5103-48	1	Pointer Cable
5105-48	2	Pointer End

## FRAME CONSOLE

6100-48	1	Mainframe
6101-48	1	Console
6102-48	1	Belt Guard - Left Side
6103-48	1	Belt Guard - Right Side
3041-48	1	Back Cover
6106-48	1	Fan Guard - Left Side
6107-48	1	Access Panel - Electrical
3022-48	2	Handlebar
3026-48	2	Locking T - Handle
6115-48	1	5 Gallon Fuel Tank
6118-48	1	Gas Cap
2111-48	1	Lower Depth Stop Rod Assembly
2119-48	1	Upper Depth Stop Rod Assembly



## **FRAME CONSOLE Continued:**

<b>PART#</b>	<b>REQUIRED</b>	<b>DESCRIPTION</b>
--------------	-----------------	--------------------

6124-48	2	Fuel Tank Hold-down Strap
---------	---	---------------------------

### **ENGINE**

7100-48	1	Hyundai 1.6-Liter, Gas
7101-48	1	Bellhousing
7102-48	1	Output Shaft/Drive Assembly
20000-48	2	Bearing - 6208
7102-C	1	Output Drive Shaft
7102-D	1	BoWex Male Coupler
7102-DG	1	BoWex Female Coupler
7103-48	1	Air Filter
7104-48	2	Air Filter Element
4183-48	2	Air Filter Hose - 2" 90° Elbow
7107-48	1	Air Filter Bracket
7108-48	1	Exhaust/Catalytic Converter
7124-48	1	Fuel Pressure Regulator
6117-48	1	Fuel Pump
6114-48	1	Fuel Filter

### **BLADEGUARD ASSEMBLY**

8100-48	1	Water Distribution Block w/Hose Fittings
8181-48	2	Outlet Water Hose - 1/4"
8102-48	1	Inlet Water Hose - 1/2"
9110-48	1	Water Valve
8104-48	1	Mud Flap
8105-48	1	20" Blade Guard
8106-48	1	26" Blade Guard
8107-48	1	30" Blade Guard
8108-48	1	36" Blade Guard

### **COOLING SYSTEM**

7711-48	1	Radiator
3009-48	1	Spal Fan
7774-48	1	Spal Fan Relay
7719-48	1	Spal Fan Relay Harness

## CONSOLE

PART#	REQUIRED	DESCRIPTION
9124-48	1	Tachometer
9101-48	1	Emergency Shutoff Switch, ABB
9106-48	1	Ignition Switch
9117-48	1	Throttle Switch
9104-48	1	Engine Service Indicator Light
9113-48	1	Console Sticker Set



### RAISE FLOW CONTROL VALVE

Inside the rear access panel above the radiator on the left side is a needle valve that allows you to adjust the raising speed. Your saw comes with the raise speed pre-set at the factory. This valve allows you to reset the speed to suit your needs.

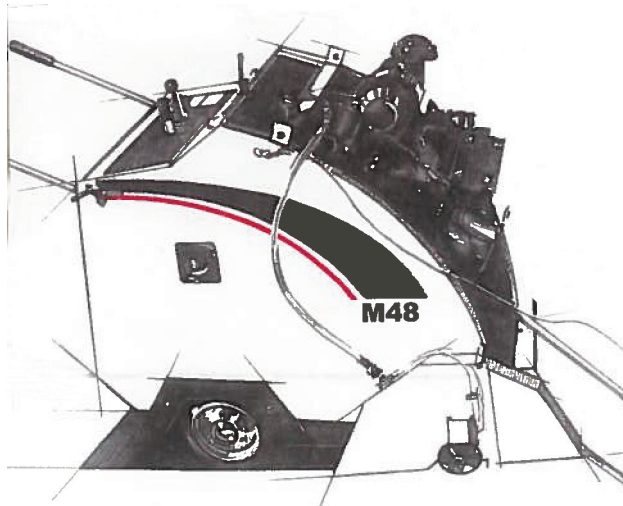

## M44D/M48 3-SPEED GEARBOX OPERATION

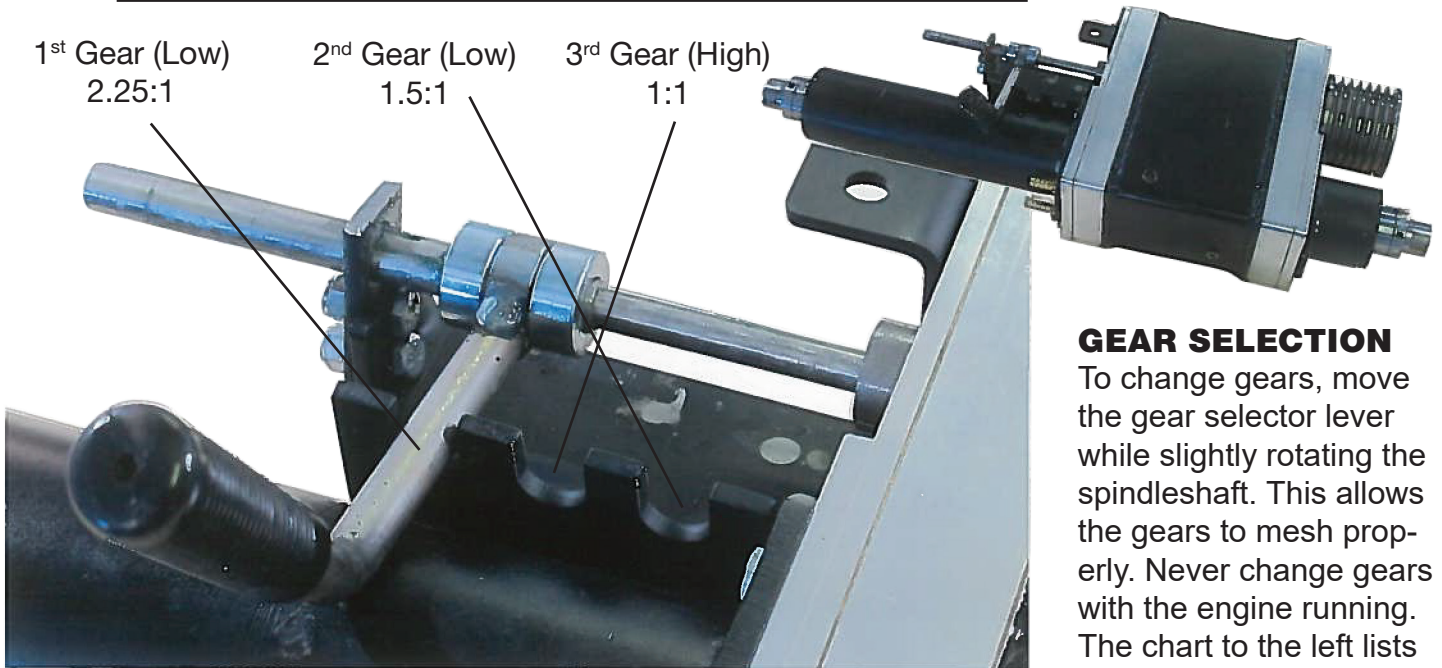

### SPINDLESHAFT SPEED W/3 SPEED GEARBOX

#### M44D KUBOTA/M48 HYUNDAI

ENGINE RPM	2600	2700	2800 Optimum	2900	3000
<b>SPINDLESHAFT SPEED – rpm*</b>					
1 <sup>st</sup> GEAR (Low Gear)	1155	1200	1244	1289	1333
2 <sup>nd</sup> GEAR	1733	1800	1867	1933	2000
3 <sup>rd</sup> GEAR (High Gear)	2600	2700	2800	2900	3000

\*Always defer to the blade manufacturer's suggested rpm for safety and best blade performance.

### BELT GUIDE

	DRIVE BELTS	FAN BELT	HYDROSTATIC PUMP BELT
<b>M44D KUBOTA</b>			
Single Speed	3VX425(6)	3VX475	3VX315
w/3-Speed	3VX400(6)	3VX475	3VX315
<b>M48 HYUNDAI</b>			
Single Speed	3VX 425 (6)	NONE	4L3400
w/3 Speed		NONE	4L3400

#### GEAR SELECTION

To change gears, move the gear selector lever while slightly rotating the spindleshaft. This allows the gears to mesh properly. Never change gears with the engine running. The chart to the left lists the spindleshaft speeds in each of the three gears – 1<sup>st</sup> Gear, Lower Gear – 2.25:1; 2<sup>nd</sup> Gear–1.5:1; and 3<sup>rd</sup> Gear, High Gear – 1:1.

#### LUBRICATION:

85W-140 Multi-Purpose Gear Oil or the equivalent.

# RAISE/LOWER VALVE ADJUSTMENT

From time to time your Raise/Lower Assembly may need some minor adjustments. If your saw creeps down when the R/L Lever is returned to it's "neutral" position after being raised, the needle valve is not closing completely.

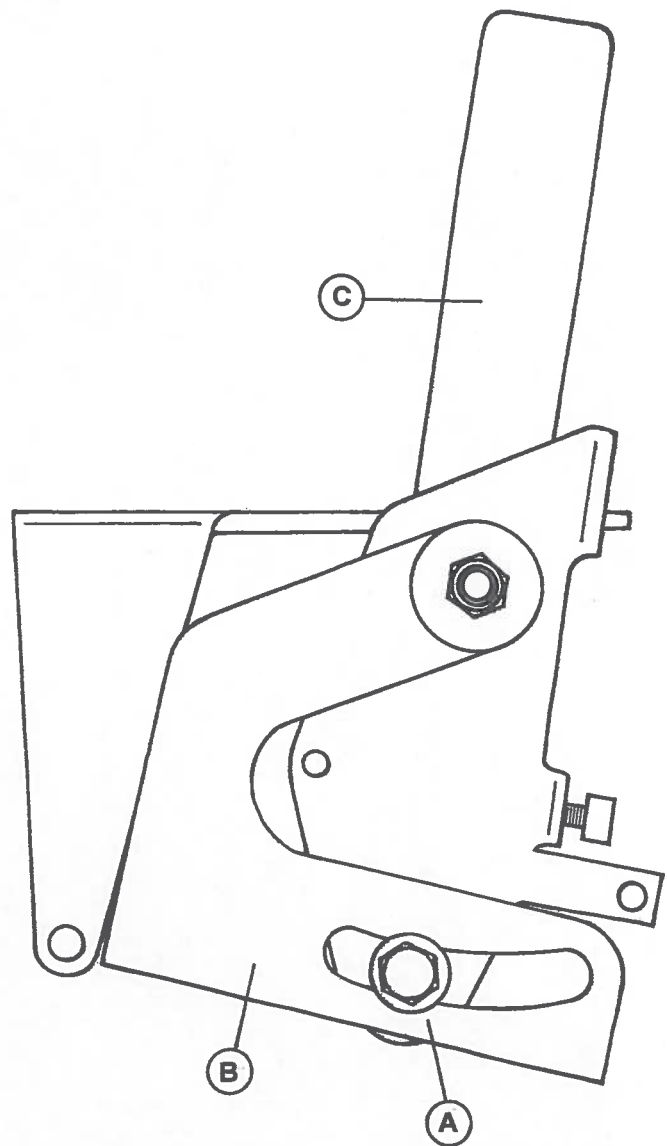

Needle valves wear over time. To adjust the valve to keep it from dropping, loosen the 5/16" bolt and nut (A) with two half inch wrenches. Rotate the arm (B) forward slightly, and re-tighten (A).

# M-48 Tank Information

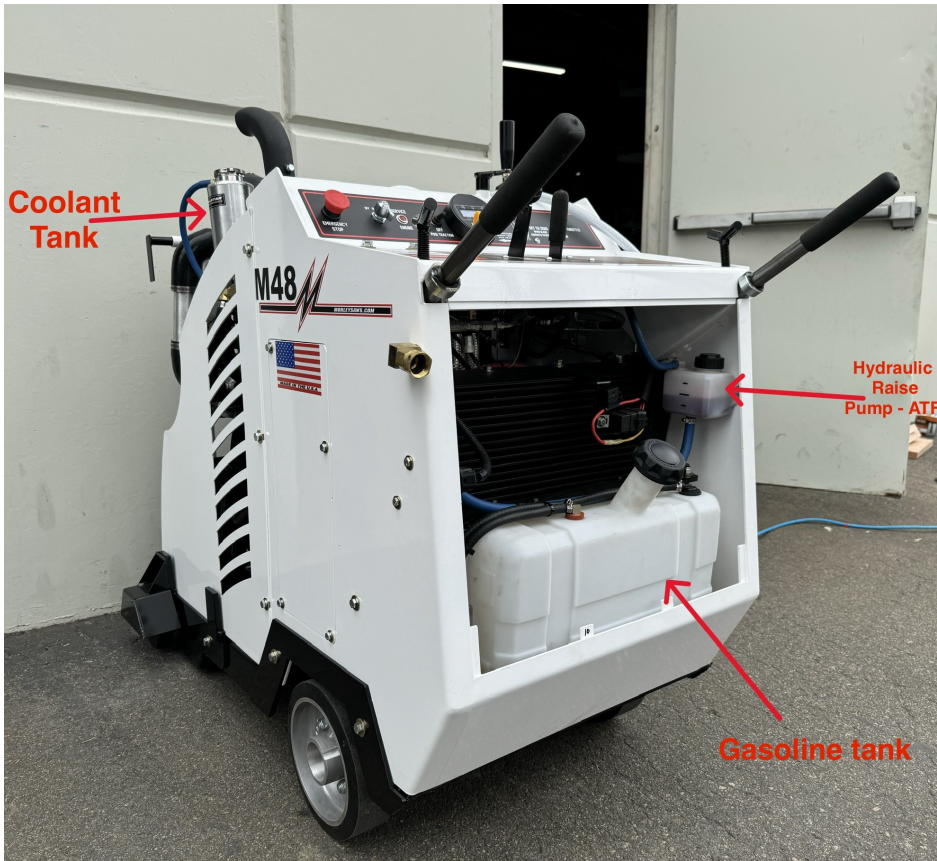

## Coolant Tank

Located at the top left side of the machine when standing at the operating controls.

Use standard antifreeze coolant.

## Hydraulic Raise Fluid Tank

Located underneath the right handle bar.

Use standard automatic transmission fluid.

## Gasoline Tank

Located bottom center when standing at the operating controls.

Use unleaded gasoline.

## Coolant Overflow Tank

Located directly in front of the coolant tank when standing at the operating controls.

**DO NOT FILL THIS TANK.**

## Hydrostatic Drive Oil Tank

Located at the front right side of the machine when standing at the operating controls, under the top cover plate.

Use 20w-50 motor oil.



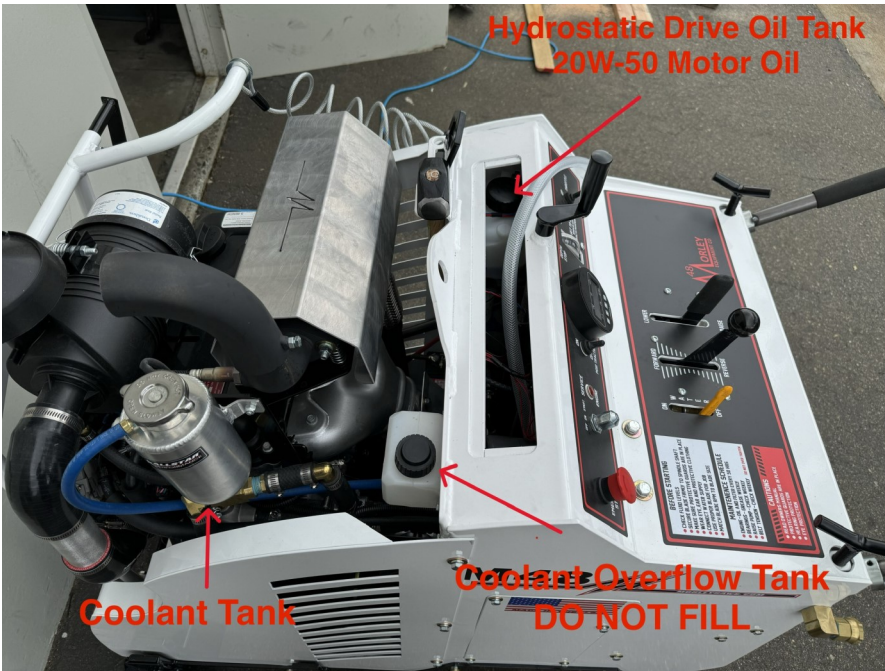

Alternate view of the coolant, coolant overflow, and hydrostatic drive oil tanks.

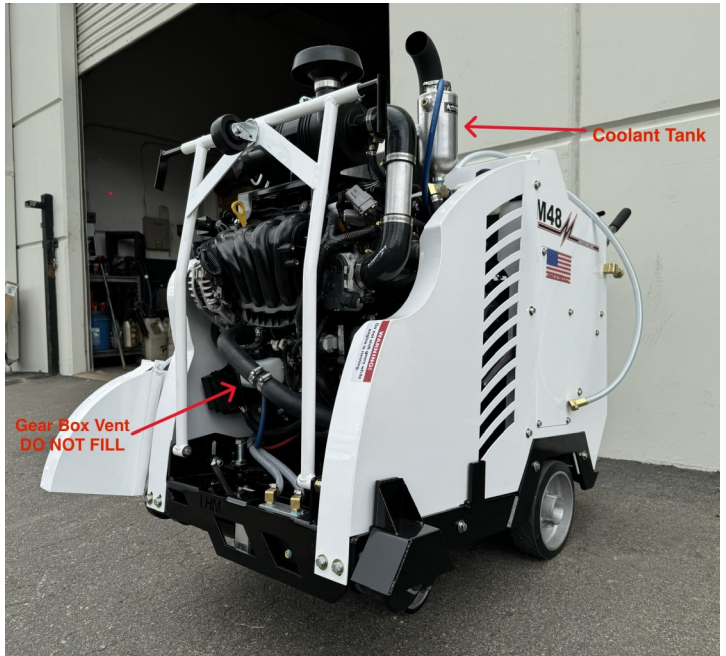

**Gear Box Venting Tank**  
 Located at the back of the machine, near the blade guard. This tank is for catching excess gear oil from the gear box.  
**DO NOT FILL THIS TANK.**

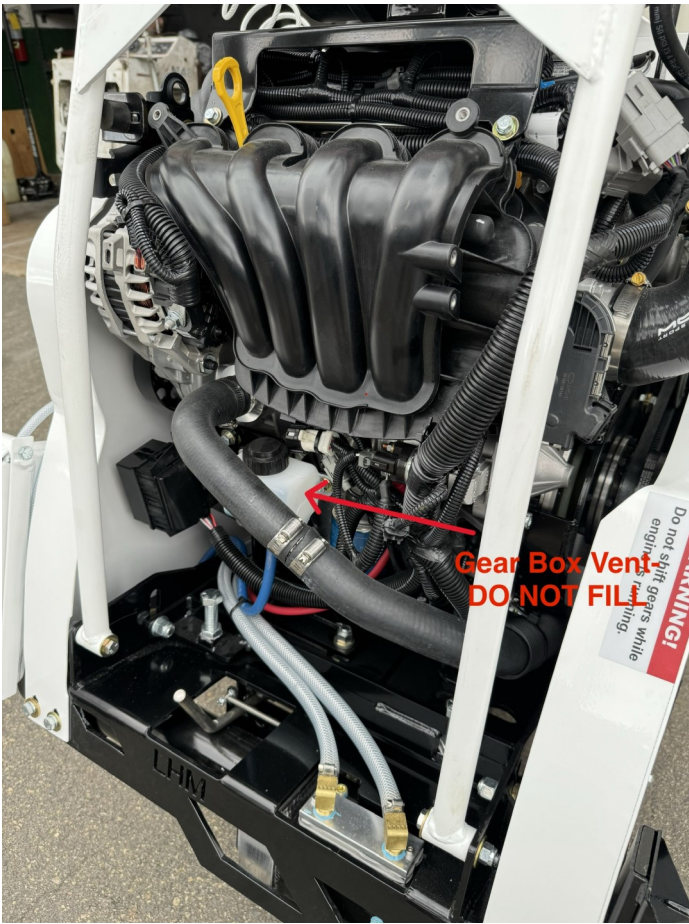



**UNITED STATES ENVIRONMENTAL PROTECTION AGENCY**  
**2023 MODEL YEAR**  
**CERTIFICATE OF CONFORMITY**  
**WITH THE CLEAN AIR ACT**

**OFFICE OF TRANSPORTATION  
 AND AIR QUALITY  
 ANN ARBOR, MICHIGAN 48105**

**Certificate Issued To: Zenith Power Products**  
 (U.S. Manufacturer or Importer)  
**Certificate Number: PZPPB01.6GAM-001**

**Effective Date:**  
 12/19/2022  
**Expiration Date:**  
 12/31/2023

Byron J. Bunker, Division Director  
 Compliance Division

**Issue Date:**  
 12/19/2022  
**Revision Date:**  
 N/A

**Manufacturer:** Zenith Power Products  
**Engine Family:** PZPPB01.6GAM  
**Mobile/Stationary Certification Type:** Mobile and Stationary  
**Fuel:** LPG/Propane  
 Natural Gas (CNG/LNG)  
 Gasoline (up to and including 10% Ethanol)  
**Emission Standards:**  
 Mobile Part 1048  
 CO ( g/kW-hr ) : 20.6  
 HC + NOx ( g/kW-hr ) : 0.8  
 NMHC + NOx ( g/kW-hr ) : 0.8  
 Stationary Part 1048  
 HC + NOx ( g/kW-hr ) : 0.8  
 CO ( g/kW-hr ) : 20.6  
 NMHC + NOx ( g/kW-hr ) : 0.8  
**Emergency Use Only : N**

Pursuant to Section 213 of the Clean Air Act (42 U.S.C. section 7547) and 40 CFR Part 60, 40 CFR Part 1048, 1065, 1068, and 60 ( stationary only and combined stationary and mobile ) and subject to the terms and conditions prescribed in those provisions, this certificate of conformity is hereby issued with respect to the test engines which have been found to conform to applicable requirements and which represent the following nonroad engines, by engine family, more fully described in the documentation required by 40 CFR Part 60, 40 CFR Part 1048 and produced in the stated model year.

This certificate of conformity covers only those new nonroad spark-ignition engines which conform in all material respects to the design specifications that applied to those engines described in the documentation required by 40 CFR Part 60, 40 CFR Part 1048 and which are produced during the model year stated on this certificate of the said manufacturer, as defined in 40 CFR Part 60, 40 CFR Part 1048. This certificate of conformity does not cover nonroad engines imported prior to the effective date of the certificate.

It is a term of this certificate that the manufacturer shall consent to all inspections described in 40 CFR 1068.20 and authorized in a warrant or court order. Failure to comply with the requirements of such a warrant or court order may lead to revocation or suspension of this certificate for reasons specified in 40 CFR Part 60, 40 CFR Part 1048. It is also a term of this certificate that this certificate may be revoked or suspended or rendered void *ab initio* for other reasons specified in 40 CFR Part 60, 40 CFR Part 1048.

This certificate does not cover large nonroad engines sold, offered for sale, or introduced, or delivered for introduction, into commerce in the U.S. prior to the effective date of the certificate.