



M44

DIESEL

OWNERS

MANUAL

SERIAL #: _____

ENGINE #: _____

WARNING

- If operated improperly, this machine may cause serious injury.
- Do not wear loose clothing when operating this machine as it may become entangled in the equipment.
- Stay clear of all moving parts when the machine is running.
- DO NOT work on this machine while the engine is running and NOT properly secured.
- ALWAYS wear safety glasses, sound protection (ear plugs), hand protection (gloves), and steel-toed boots when operating this machine.
- NEVER stand in water while operating this machine (ELECTRIC MODEL).
- ALWAYS use properly grounded power cords (ELECTRIC MODEL).
- Power cords should ALWAYS be the proper wire gauge for each particular application (ELECTRIC MODEL).
- ALL extension cords should be plugged into a “ground fault interrupter” (ELECTRIC MODEL).
- NEVER use extension cords that are in any way damaged, frayed or cut (ELECTRIC MODEL).
- ALWAYS use the proper cutting rpm as specified by your blade manufacturer.
- ALWAYS shut off the machine before changing the blade (UNPLUG ELECTRIC MODEL before changing the blade).
- Insure proper position and security of ALL safety guards before operating this machine.
- ALWAYS inspect the machine before use for safe operation.
- FIRE HAZARD! Inspect for any leaking fluids before starting the machine.

WARNING Continued

- DO NOT attempt to off-load any piece of equipment on uneven ground of any degree of slope. DO NOT leave equipment unattended on uneven ground. Injury or death may occur.

THIS EQUIPMENT SHOULD NOT BE OPERATED BY ANYONE UNDER THE AGE OF 18.

- DO NOT jump-start a dead battery on this machine. The process of jump-starting a discharged (dead) battery can, under certain conditions, result in a battery explosion from the ignition of hydrogen gas, resulting in injury or death.

LIMITED WARRANTY

WARRANTY:

Morley Equipment Company warrants that at the time of shipment, the product manufactured by Morley Equipment Company and sold hereunder shall be free from defects in material and workmanship.

WARRANTY ADJUSTMENTS:

Morley Equipment Company agrees to repair or furnish any faulty component within 30-days from date of purchase provided the machine is operated and maintained in accordance with Morley Equipment Company Owners and Engine Manuals and Operating Instructions.

If examinations by Morley Equipment Company prove a defect within Warranty, receipt verifying purchase date and serial numbers are required to obtain Adjustment. One year Warranty on major components (such as engine, drive motors, hydraulic pump, hydraulic motor and etc.) with an authorized service facility. See Owners Manual for Warranty from the manufacturer of that product.

No product will be accepted for return or replacement without prior authorization by Morley Equipment Company. Products returned are addressed to:

**Morley Equipment Company, 41161 Sandalwood Circle, Murrieta, CA 92562:
(951) 894-5558.**

EXCLUSIONS FROM WARRANTY:

This Warranty does not extend to any product supplied by Morley Equipment Company which has been subjected to misuse, neglect, accident, improper installation or used in violation of instructions provided by Morley Equipment Company.

M44D SAW INFORMATION

1. This Manual provides the basic instructions for the operation and maintenance of the M44D concrete saw. An Engine Manual is also provided with each saw.

2. **M44-D - WATER COOLED DIESEL:**

ENGINE: Kubota V1505-TE 1.5-Liter Turbocharged Diesel
 Drive Unit: Hydrostatic Transmission
 Water Pump: Self-priming Electric (Optional)
 Spindle: 1-7/16"
 Arbor Size: 1" with 1/4" Keys
 Blade Capacity: 14-to 36-inch Diameter
 Control Depth: Hydraulic Raise & Lower, Depth Gauge and Locking Stop
 Fuel Capacity: 5-Gallons
 Weight: Single Speed: 1,040 Lbs, 3-Speed: 1,130 Lbs
 Length: 43"
 Width: 29" w/Quick Detach Spindle
 Height: 44"



OPTIONAL EQUIPMENT

1. 3-Speed Gearbox
2. Night Light
3. Bladeguards - 26", 30", and 36"
4. Electric Water Pump

3. The new machine was test-run before leaving Morley Equipment Company, however, the engine should be checked with the Engine Manual so that the correct routine is followed at all times. Check all fluid levels. This is very important during the initial running-in of the engine as specified in the Engine Manual.

4. **LUBRICATION/SERVICE CHART**

ITEM	CHECK	LUBRICANT
Hydrostatic Transmission (F/R)	Monthly	20W-50 Motor Oil
Air Filter	Weekly	Service as required
Hydraulic Pump (R/L)	Monthly	ATF
Spindle Bearings	Daily	Grease
Pivot Axle	Weekly	Grease
Front Wheels	Weekly	Grease
Radiator	Daily	Squirt debris out of cooling fins

5. To adjust or replace the belts, loosen the 1/2" "pinch" bolts, one on either side at the front of the motor base plate, and the two 5/8" bolts that run vertical at the front of the motor plate. This allows the motor to be raised or lowered, loosening the belts for replacement or tensioning. Then raise the motor and tighten the bolts after belt replacement or to adjust tension. It is important that the tension is just enough to drive without slipping. Too tight shortens bearing life, too loose shortens belt life (Spindleshft Belts – (6) 3VX425; w/3-Speed Gearbox – 3VX400).

CONTROL OPERATING INSTRUCTIONS

1. **WATER SUPPLY:** Connect the water supply to the "inlet hose (1/2-inch), " open the water valve and make sure that "outlet (1/4-inch)," hoses mounted in the bladeguard are free of obstructions. Blow out the water lines before operation in freezing conditions.
2. **RAISE/LOWER:** By pulling back the Raise/Lower lever a momemtary switch activates an electric-over-hydraulic pump to raise the saw. Push the lever foward to lower the saw. You can control the lowering speed by opening the valve gradually. For adjusting the handle assembly, see accompanying instruction.
3. **SPEED CONTROL:** The Forward/Reverse lever determines forward and reverse speeds, with a "neutral" dynamic brake position in between. By pushing the speed control lever foward, the saw will move forward at variable speeds, pulling the lever back does the same in reverse.
4. **BLADE FITTING:** Raise the saw to accommodate your choice of blades - 14" to 36". Lift off the bladeguard with engine off. Remove the spindle nut with the spindle nut wrench provide with the saw and then the outer blade collar. Inspect both collars so they will seat flush with the blade. Place blade on spindleshft and align with collar pin in inner collar, now replace outer collar and spindle nut - tighten by striking spindle nut wrench with provided hammer and finally, replace bladeguard.
5. **STARTING THE ENGINE:** This should be done as explained in the Engine Manual.
6. **POSITIONING THE SAW:** The saw may be maneuvered in several ways. Position the handle bars to suit the operator's leverage (Note: this is a rear-pivot saw). The independent drive motors, the function as a differential, allow the saw to be rotated by lifting the front wheels off the ground by pushing down on the handle bars and rotating

CONTROL OPERATING INSTRUCTIONS Continued:

the saw on the rear wheels in the desired direction, left or right, and positioning for the next cut. The saw may also be positioned by using the “wheel-borrow” approach - lift the rear wheels and rotate to the desired position using the front wheels to pivot the saw.

7. **CUTTING:** Lay out the cuts using a chalk line or string and paint. Use the pointer guide as your saw cut “gun site.” Bring the engine to the blade manufacturer’s recommended RPM. Position the saw to initiate the cut. When aligned and positioned, turn on the water and lower the saw to desired cut depth, then move the saw forward to a comfortable cutting speed - don’t “labor” the blade. Water amount is an acquired science - ask your blade manufacturer for recommendations. Reading the slurry is your key to cost-effective cutting - just the right amount of water is needed for cutting speed and blade life (a blade’s accumulated inch-feet cut). It is recommended to step-cut - take several passes to reach desired depth - this also benefits blade life. Once the chalked-out cut has been completed, return the Forward/Reverse lever to the “neutral” position and using the Raise/Lower lever, raise the saw out of the cut. If step-cutting, return the saw to the original insertion point and lower the blade to the secondary depth and repeat the cut, then raise the blade as before and position the saw for the next cut.
8. **CLEANING:** The entire saw should be thoroughly washed weekly or as required. Use caution to prevent water from association with the fuel tank and electrical system. WD40 works well as a water dispersant. Be sure to squirt any debris - dust, slurry, etc. - out of the radiator’s cooling element.
9. **STORAGE:** Always lubricate the saw after cleaning.
10. **CALIBRATION:** Always check alignment. The spindleshaf and rear axles must be aligned to insure the saw travels straight and the blade moves parallel to the rear wheels.
11. **REPLACEMENT PARTS:** All replacement parts must be ordered from Morley Equipment Company to effect Warranty. Always supply Model and Serial Number when ordering parts.
12. **QUESTIONS AND CONCERNS:** Should you have any questions relative to the operation or servicing your equipment, do not hesitate to contact **Morley Equipment Company** at (951) 894-5558; or Email us at morleyequipco@gmail.com. A Parts List for the saw is also available on-line at www.morleysaws.com

M44 PARTS LIST

SPINDLESHAFT ASSEMBLY

PART	REQUIRED	DESCRIPTION
1100-44D	1	Spindleshaft
1101-44D	2	Pillow-blocking Bearing
1102-44D	2	Inner Collar
1103-44D	2	Outer Collar
1104-44D	1	Left-hand Nut
1105-44D	1	Right-hand Nut
1106-44D	1	Sheave
1107-44D	1	Bushing
1108-44D	1	Key - 3/8"
1109-44D	2	Key - 1/4"
1110-44D	6	3VX425 Belt; 3-Speed Gearbox - 3VX400
1111-44D	1	L hand Spindle Stud
1112-44D	1	R hand Spindle Stud

FRONT AXLE ASSEMBLY

2100-44D	1	Weldment
2101-44D	2	Axle - 1"
2102-44D	2	Wheel - 6x2"
2103-44D	2	Collar - 1"
2104-44D	2	Pillow-block Bearing - 1"
2105-44D	1	Pin - 5/8"x 3.5"
2106-44D	1	Depth Gauge, Cable, Spring
2107-44D	1	Pin - 5/8x3"

HYDRAULIC RAISE/LOWER ASSEMBLY

3100-44D	1	Pump Motor
3101-44D	1	Flow Control Valve
3102-44D	1	Hydraulic Cylinder
3103-44D	1	Raise/Lower Handle Assembly
3104-44D	1	Solenoid

HYDROSTATIC DRIVE ASSEMBLY

PART	REQUIRED	DESCRIPTION
4100-44D	1	Pump
4101-44D	2	Drive Motor
4102-44D	1	Traction Manifold
4103-44D	2	Wheel Hub
4104-44D	2	Wheel - 10x3"
4105-44D	1	Filter Assembly
4106-44D	1	Filter
4107-44D	1	Reservoir - Plastic
4108-44D	1	Forward/Reverse Friction Lever Assembly
4109-44D	1	Cable
4110-44D	2	Cable End - Balljoint
4111-44D	1	Wheel Motor Bracket
4112-44D	1	Hydrostatic Drive Pump Bracket
4113-44D	1	Hydrostatic Pump Belt – 3VX315

POINTER ASSEMBLY

5101-44D	1	3" Caster
5102-44D	2	Delrin Bushing
5103-44D	2	Pointer Ends
5104-44D	1	Lift Cable
5105-44D	1	Pointer Weldment

FRAME CONSOLE

6100-44D	1	Mainframe
6101-44D	1	Console
6102-44D	1	Belt Guard - Left Side
6103-44D	1	Belt Guard - Right Side
6104-44D	1	Air Intake - Rear
6105-44D	1	Air Exhaust - Left Side
6106-44D	1	Access Panel - Electrical
6107-44D	2	Handlebar
6108-44D	2	Locking T - Handle
6109-44D	1	Fuel Tank
6110-44D	1	Gas Cap
6111-44D	1	Depth Stop Rod Assembly
6112-44D	1	Depth Stop Handle Assembly

FRAME CONSOLE Continued:

PART	REQUIRED	DESCRIPTION
-------------	-----------------	--------------------

6115-44D	2	Fuel Tank Hold-down Strap
----------	---	---------------------------

ENGINE

7100-44D	1	Kubota V1505-TE Turbocharged 1.5-Liter Diesel
7101-44D	1	Bellhousing - Inner/Outer
7102-44D	1	Output Shaft/Drive Assembly
7102-44D-A	2	Bearing - Output/Drive Assembly
7102-44D-B	1	Shaft - Output/Drive Assembly
7102-44D-C	1	BoWex Male Coupler Output/Drive Assembly
7102-44D-D	1	BoWex Female Coupler Output/Drive Assembly
7103-44D	1	Air Filter
7104-44D	2	Air Filter Element
7105-44D	2	Hose - 90-Degree Elbow
7106-44D	1	Hose Coupler
7107-44D	1	Air Filter Bracket
7110-44D	1	Murphy Switch - Overheat Reset Switch
7111-44D	1	Fuel Filter

COOLING SYSTEM

7111-44D	1	Radiator
7112-44D	1	Fan Blade
7113-44D	1	Fan Shaft
7114-44D	1	Idler Pulley
7115-44D	1	Spring
7116-44D	1	Fan Belt – 3VX475

BLADEGUARD ASSEMBLY

8100-44D	1	Water Distribution Block W/Hose Fittings
8181-44D	2	Outlet Water Hose - 1/4"
8102-44D	1	Inlet Water Hose - 1/2"

BLADEGUARD ASSEMBLY Continued:

PART	REQUIRED	DESCRIPTION
8103-44D	1	Water Valve
8104-44D	1	Mud Flap
8105-44D	1	20" Bladeguard
8106-44D	1	26" Bladeguard
8107-44D	1	30" Bladeguard
8108-44D	1	36" Bladeguard

CONSOLE

9101-44D	1	Emergency Shutoff Switch
9107-44D	1	Tachometer/Hour Meter
9108-44D	1	Ignitions Switch
9109-44D	1	Push/Pull Engine Speed Control Cable
9110-44D	1	Temperature Gauge
9111-44D	1	Amp Indicator Light
9112-44D	1	Oil Pressure Indicator Light
9113-44D	1	Upper Console Sticker
9114-44D	1	Lower Console Sticker

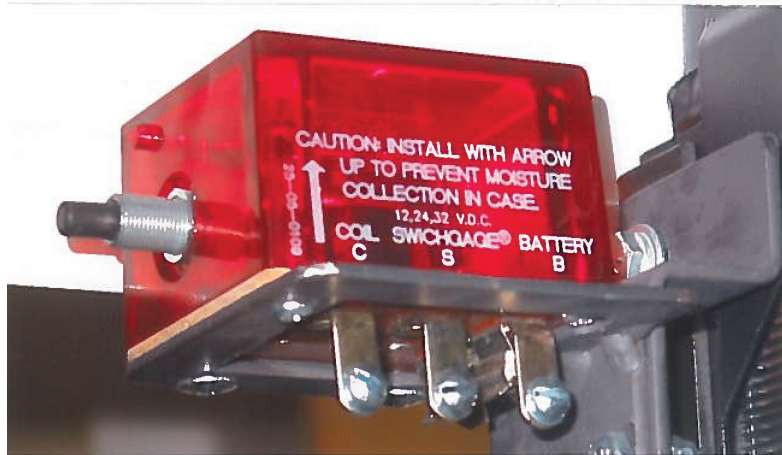

ENGINE TEMPERATURE RESET SWITCH

Just inside the rear access panel on the left side is a Murphy Switch that prevents engine overheating. When the Temperature Gauge senses excessive engine heat, the magnetic "trip" switch shuts off the fuel supply, killing the engine. When the engine has cooled sufficiently, hit this reset button and the engine will restart.

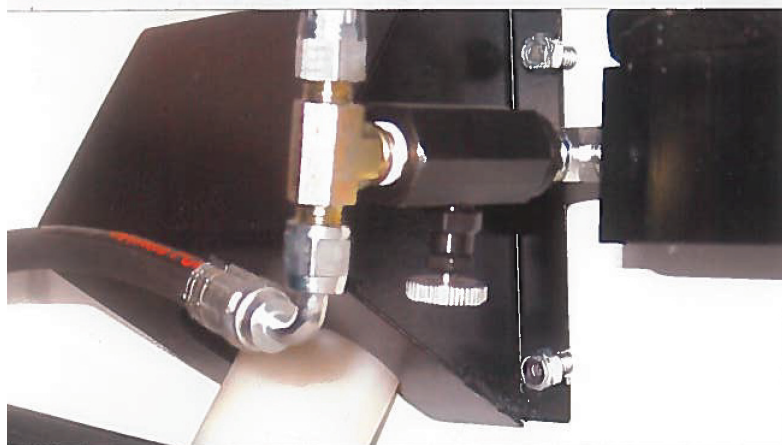

RAISING FLOW CONTROL VALVE

Just inside the rear access panel on the right side is a needle valve that allows you to adjust the raising speed imparted by the Raise/Lower Lever. Your saw comes with the raise speed pre-set at the factory. This valve allows you to reset the speed to suit your needs.

M44D/M48 3-SPEED GEARBOX OPERATION

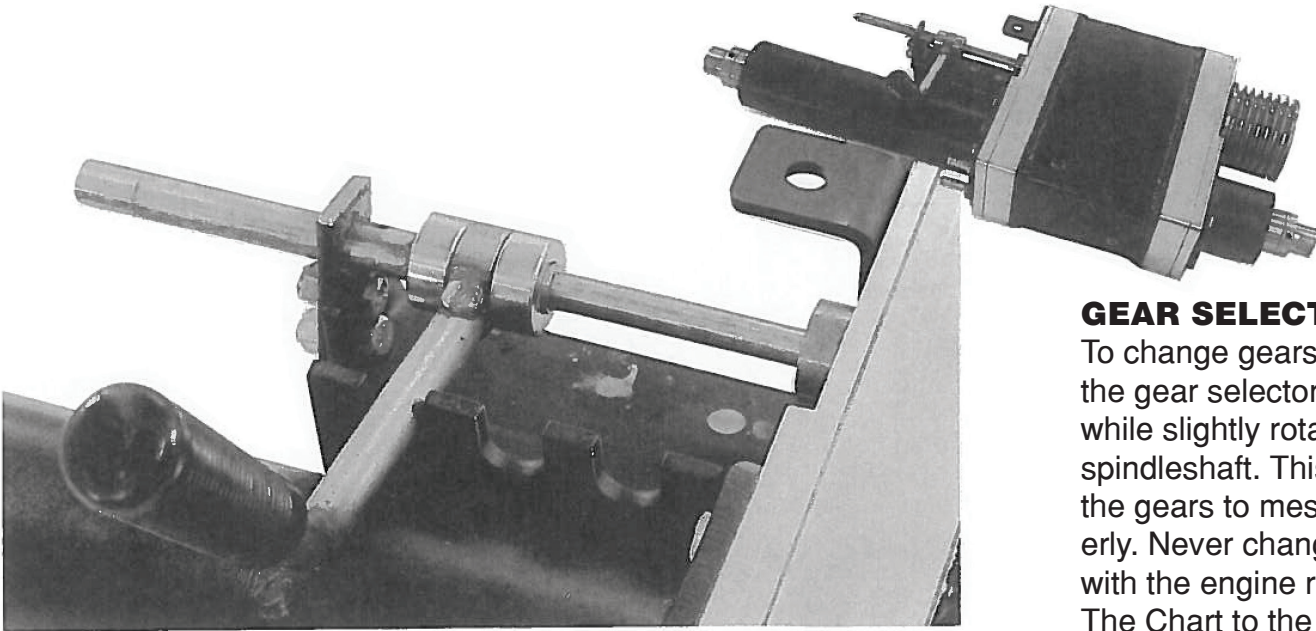

SPINDLESHAFT SPEED W/3 SPEED GEARBOX

M44D KUBOTA/M48 HYUNDAI

ENGINE RPM	2600	2700	2800 Optimum	2900	3000
SPINDLESHAFT SPEED – rpm*					
1 st GEAR (Low Gear)	1155	1200	1244	1289	1333
2 nd GEAR	1733	1800	1867	1933	2000
3 rd GEAR (High Gear)	2600	2700	2800	2900	3000

*Always defer to the blade manufacturer's suggested rpm for safety and best blade performance.

BELT GUIDE

	DRIVE BELTS	FAN BELT	HYDROSTATIC PUMP BELT
M44D KUBOTA			
Single Speed	3VX425(6)	3VX475	3VX315
w/3 Speed	3VX400(6)	3VX475	3VX315
M46 HYUNDAI			
Single Speed	3VX400(7)	NONE	4L3400
w/3 Speed	3VX400(7)	NONE	4L3400

GEAR SELECTION

To change gears, move the gear selector lever while slightly rotating the spindleshaft. This allows the gears to mesh properly. Never change gears with the engine running. The Chart to the left, lists the spindleshaft speeds in each of the three gears – 1st Gear, Lower Gear – 2.25:1; 2nd Gear – 1.5:1; and 3rd Gear, High Gear – 1:1.

LUBRICATION:

85W-140 Multi-Purpose Gear Oil or the equivalent.

RAISE/LOWER **VALVE** **ADJUSTMENT**

From time to time your Raise/Lower Assembly may need some minor adjustments. If your saw creeps down when the R/L Lever is returned to its “neutral” position after being raised, the needle valve is not closing completely. The following adjustment is an easy fix.

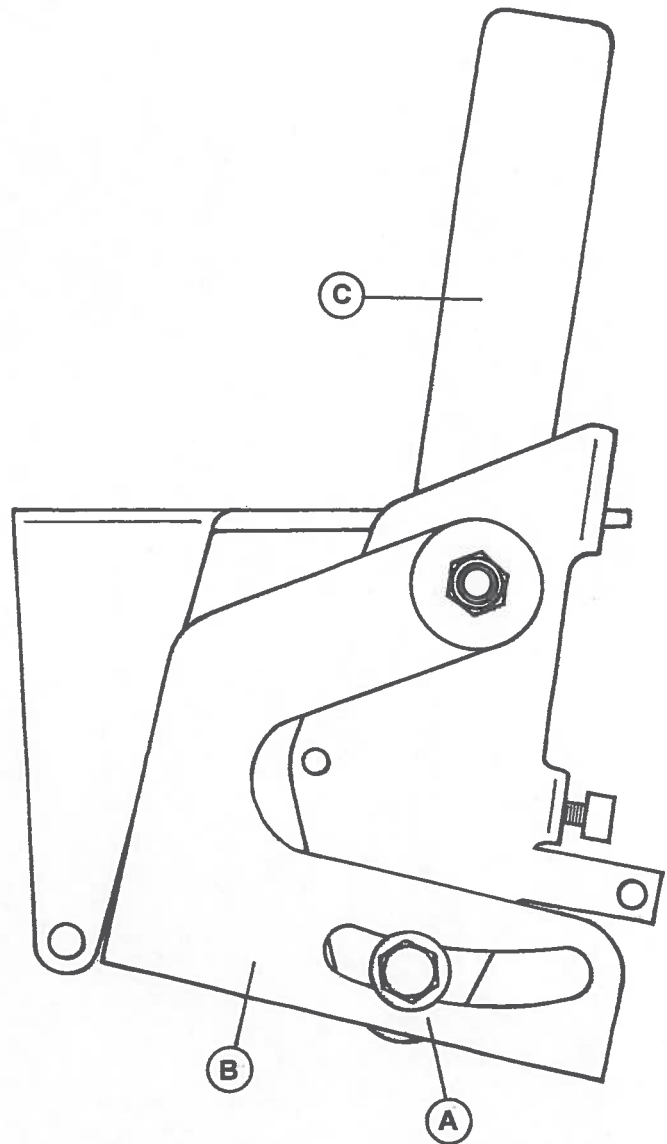

Needle valves are known to take a “set” after continued use, meaning the stops (open/close) change slightly so the R/L Lever (C) doesn’t completely close the valve or open the valve when the Lever reaches its stops. Opening the valve to lower the saw is not the issue, its the valve not closing completely that presents the problem.

By loosening this 7/16” nut (A) you can rotate the adjusting arm (B) to close the needle valve. Once that adjustment has been made, tighten the nut. Now, when the R/L Lever is pulled all the way back as the saw is raised and a spring then returns the Lever back to its original “neutral” position, the saw will no longer creep down.